



**KNOXVILLE/KNOX COUNTY METROPOLITAN PLANNING COMMISSION  
SUBDIVISION REPORT - CONCEPT/USE ON REVIEW**

▶ **FILE #:** 1-SF-15-C  
1-J-15-UR

**AGENDA ITEM #:** 12  
**AGENDA DATE:** 1/8/2015

▶ **SUBDIVISION:** BAKERTOWN STATION  
▶ **APPLICANT/DEVELOPER:** BENCHMARK ASSOCIATES, INC.  
**OWNER(S):** Ball Camp Residential Partners

**TAX IDENTIFICATION:** 91 25601 [View map on KGIS](#)  
**JURISDICTION:** County Commission District 3  
**STREET ADDRESS:**

▶ **LOCATION:** South side of Ball Camp Pk., east side of Bakertown Rd.

**SECTOR PLAN:** Northwest County  
**GROWTH POLICY PLAN:** Planned Growth Area  
**WATERSHED:** Beaver Creek

▶ **APPROXIMATE ACREAGE:** 17.65 acres

▶ **ZONING:** PR (Planned Residential)

▶ **EXISTING LAND USE:** Attached and detached residential condominium development

▶ **PROPOSED USE:** Detached dwellings

**SURROUNDING LAND USE AND ZONING:** Property in the area is A agricultural, PR and RA residential and I industrial. Development in the area consists of detached dwellings. The proposed Schaad Rd. extension is located just to the north of this site.

▶ **NUMBER OF LOTS:** 63

**SURVEYOR/ENGINEER:** Benchmark Associates, Inc.

**ACCESSIBILITY:** Access is via Ball Camp Pk., a minor collector street with a pavement width of 19' within a 40' wide right-of-way.

▶ **SUBDIVISION VARIANCES REQUIRED:**  
1. Reduce the minimum required right-of-way for a JPE from 40' to 30'  
2. Reduce the horizontal curve radius from 250' to 150' at sta. 6+50 of Train Station Wy.  
3. Reduce the horizontal curve radius from 250' to 100' at sta.2+50 of Train Station Wy.

**STAFF RECOMMENDATION:**

▶ **APPROVE** variances 1 - 3 because the site's topography restricts compliance with the Subdivision Regulations, and the proposed variances will not create a traffic hazard.

**APPROVE the Concept Plan subject to 4 conditions:**

- 1. Connection to sanitary sewer and meeting all other applicable requirements of the Knox County Health Dept.
- 2. Place a note on the final plat that all lots will have access from the internal street system only

3. Any documents required to amend the horizontal property regime and master deed, homeowners association or the maintenance agreements for the joint permanent easements, stormwater management facilities and any other commonly held assets shall be recorded prior to or with the final plat, with the recording information for the documents being noted on the final plat
4. A final plat based on this concept plan will not be accepted by MPC for review until certification of the design plan has been submitted to MPC staff

► **Approve the request for up 63 detached dwellings (62 units on individual lots and 1 unit on an existing lot that already has 3 dwelling units) as shown on the development plan subject to 1 condition**

1. Meeting all applicable requirements of the Knox county Zoning Ordinance

With the condition noted, this plan meets the requirements for approval of a Concept Plan and a Use-on-Review within the PR (Planned Residential) zoning district.

**COMMENTS:**

In 2005 MPC approved a plan that would permit a subdivision that would contain 102 lots and a condominium development that would permit up to 96 attached dwellings. The subdivision has been developed and all of the lots have been recorded. Nineteen of the proposed 96 condominium units have been constructed. This plan proposes to change the remainder of the area that was to be devoted to condominiums to a detached residential subdivision. The conversion of the condos to detached dwellings will result in a loss of 9 dwellings. Eighty-seven dwellings will be developed in the same area where 96 dwellings had been approved.

**EFFECT OF THE PROPOSAL ON THE SUBJECT PROPERTY, SURROUNDING PROPERTY AND THE COMMUNITY AS A WHOLE**

1. The proposed subdivision will have minimal impact on local services since water and sewer will be provided to this site.
2. The proposed detached residential subdivision at a density of 3.74 du/ac this phase, 2.61 du/ac for the entire project is consistent in use and density with the zoning of the property.
3. The proposed low density residential zoning and development is compatible with the scale and intensity of the surrounding development and zoning pattern.

**CONFORMITY OF THE PROPOSAL TO CRITERIA ESTABLISHED BY THE KNOX COUNTY ZONING ORDINANCE**

1. The proposed detached residential subdivision with the recommended conditions meets the standards for development within a PR Zone and all other requirements of the Zoning Ordinance.
2. The proposed subdivision is consistent with the general standards for uses permitted on review: The proposed development is consistent with the adopted plans and policies of the General Plan and Sector Plan. The use is in harmony with the general purpose and intent of the Zoning Ordinance. The use is compatible with the character of the neighborhood where it is proposed. The use will not significantly injure the value of adjacent property. The proposed subdivision will not draw significant traffic through residential neighborhoods.

**CONFORMITY OF THE PROPOSAL TO ADOPTED PLANS**

1. The Northwest County Sector Plan designates this property for low density residential use. The PR zoning approved for the property allows consideration of a plan for up to 4.0du/ac . The proposed subdivision with its overall density of 2.61du/ac is consistent with the Sector Plan and the proposed zoning designation.
2. The site is located within the Planned Growth Area on the Knoxville-Knox County-Farragut Growth Policy Plan

ESTIMATED TRAFFIC IMPACT: 668 (average daily vehicle trips)

Average Daily Vehicle Trips are computed using national average trip rates reported in the latest edition of "Trip Generation," published by the Institute of Transportation Engineers. Average Daily Vehicle Trips represent the total number of trips that a particular land use can be expected to generate during a 24-hour day (Monday through Friday), with a "trip" counted each time a vehicle enters or exits a proposed development.

ESTIMATED STUDENT YIELD: 33 (public and private school children, ages 5-18 years)

Schools affected by this proposal: Amherst Elementary, Karns Middle, and Karns High.

- School-age population (ages 5–18) is estimated by MPC using data from a variety of sources.
- While most children will attend public schools, the estimate includes population that may be home-schooled, attend private schools at various stages of enrollment, or drop out of the public system.
- Students are assigned to schools based on current attendance zones as determined by Knox County Schools. Zone boundaries are subject to change.
- Estimates presume full build-out of the proposed development. Build-out is subject to market forces, and timing varies widely from proposal to proposal.
- Student yields from new development do not reflect a net addition of children in schools. Additions occur incrementally over the build-out period. New students may replace current population that ages through the system or moves from the attendance zone.
- School capacities are subject to change by Knox County Schools through building additions, curriculum or scheduling changes, or amendments to attendance zone boundaries.

MPC's approval or denial of this concept plan request is final, unless the action is appealed to Knox County Chancery Court. The date of the Knox County Chancery Court hearing will depend on when the appeal application is filed.

MPC's approval or denial of this use on review request is final, unless the action is appealed to the Knox County Board of Zoning Appeals. The date of the Knox County Board of Zoning Appeals hearing will depend on when the appeal application is filed.

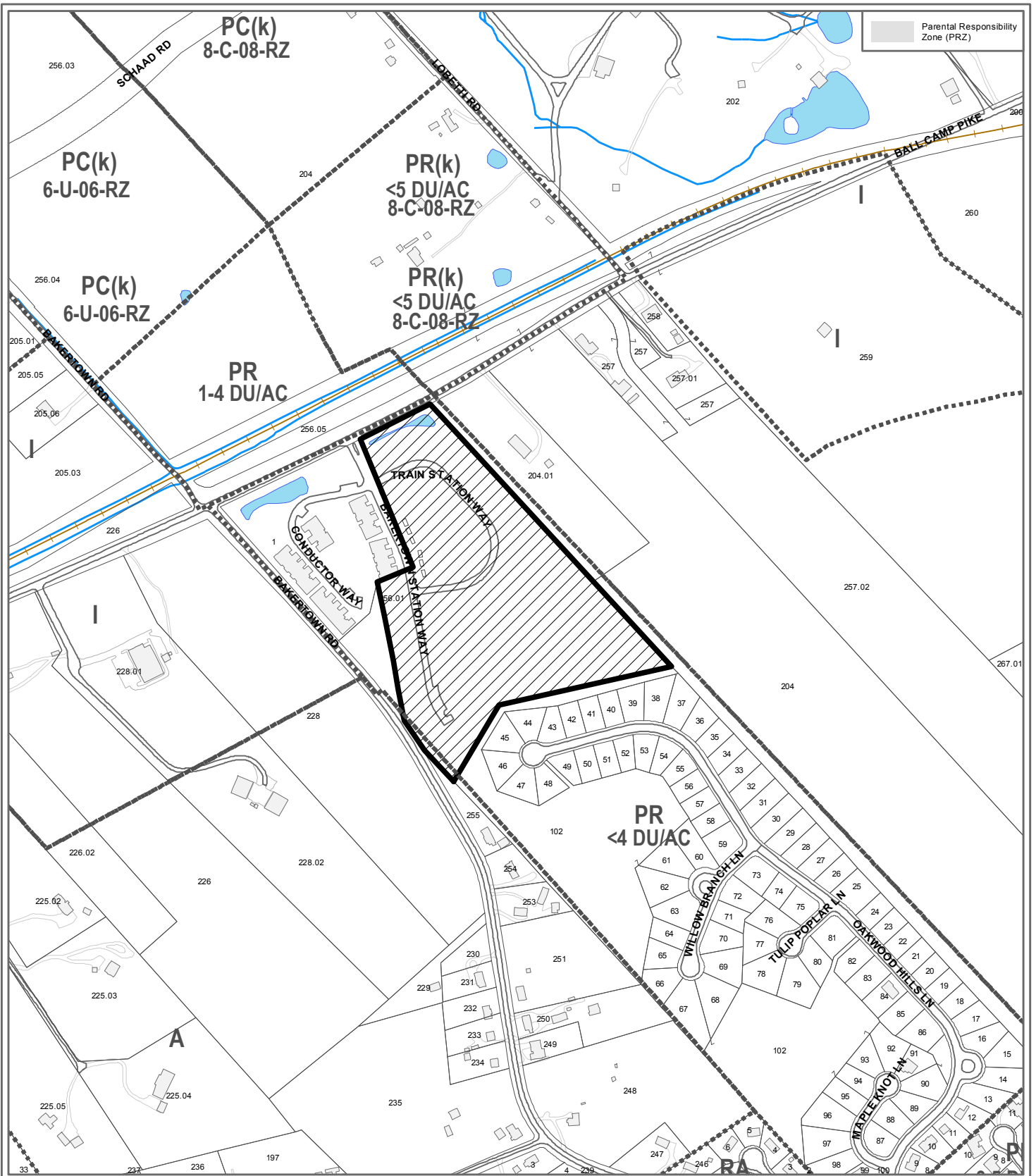

**1-SF-15-C / 1-J-15-UR  
CONCEPT PLAN/USE ON REVIEW**

Petitioner: Benchmark Associates, Inc.  
Bakertown Station



Detached dwellings in PR (Planned Residential)

Map No: 91

Jurisdiction: County

Original Print Date: 12/22/2014      Revised:  
Metropolitan Planning Commission \* City / County Building \* Knoxville, TN 37902

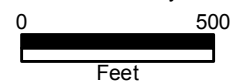

TENNESSEE STATE PLANE GRID

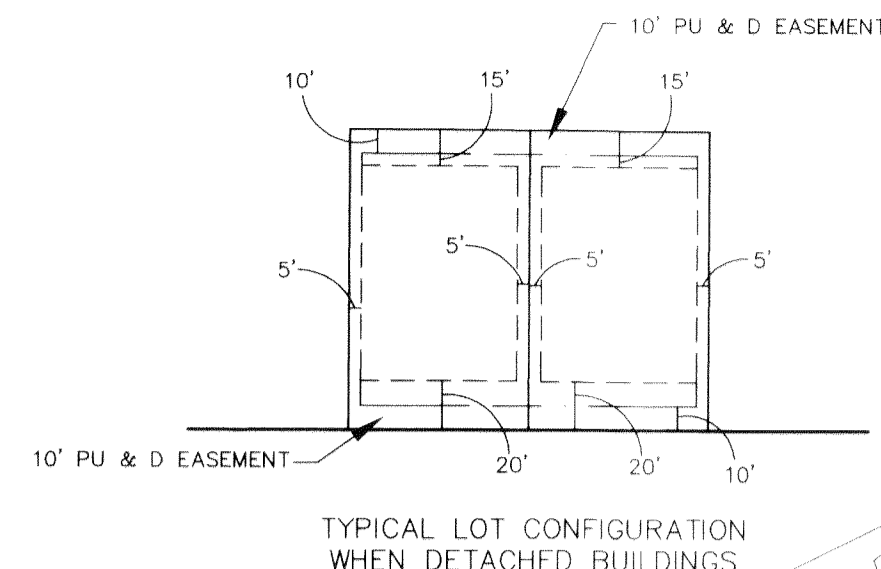
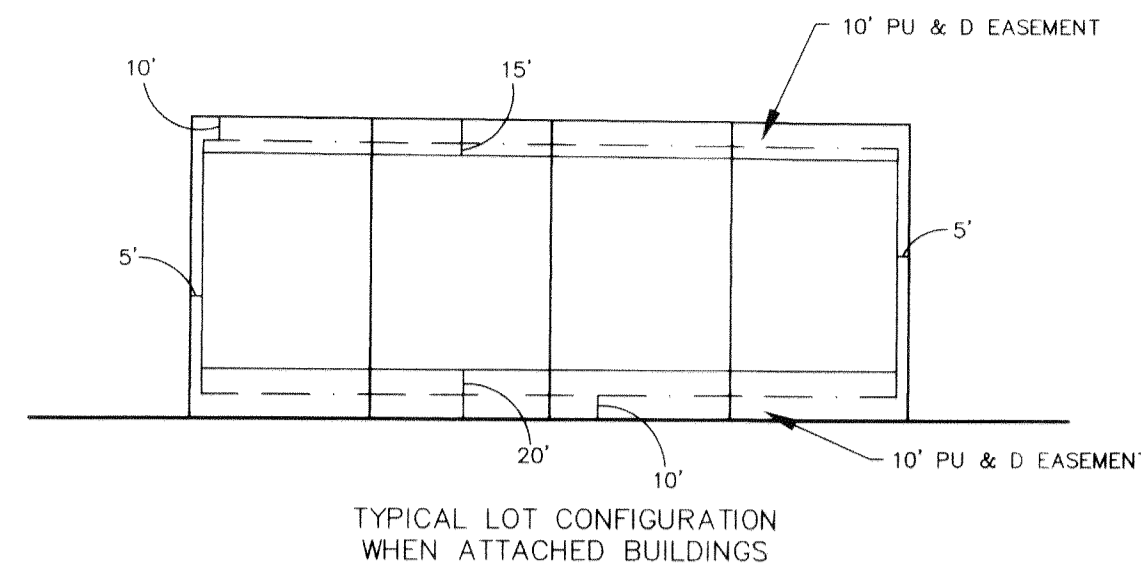
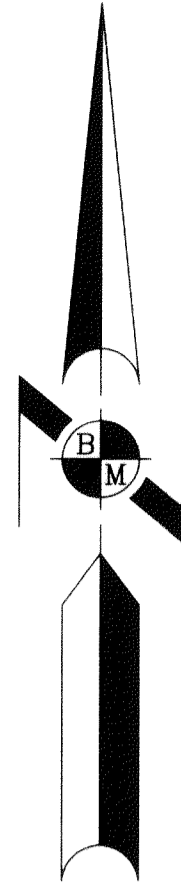

VARIANCES:

- 1) REDUCE HORIZONTAL RADI FROM 250' TO 100' ON TRAIN STATION WAY BETWEEN STATION 1+54.58 AND STATION 2+82.93.
- 2) REDUCE HORIZONTAL RADI FROM 250' TO 150' ON TRAIN STATION WAY BETWEEN STATION 5+12.97 AND STATION 8+38.71.

NOTES:

1. PROPERTIES ARE SUBJECT TO ANY AND ALL RESTRICTIONS, COVENANTS, CONDITIONS, PLANNING COMMISSION ORDINANCES, RIGHT-OF-WAYS, AND ALL EASEMENTS, IF ANY, AFFECTING SAME.
2. PROPERTIES BOUNDARIES SHOWN REPRESENT INSTRUMENTS OF RECORD FOUND IN INSTRUMENT #200507250007480 AND INSTRUMENT #200610310037488, ALL OF THE REGISTER'S OFFICE OF KNOX COUNTY, TENNESSEE.
3. 15' SANITARY SEWER EASEMENTS ALONG ALL SANITARY SEWER LINES. LIMITS OF EASEMENTS WILL BE PLATTED AT 15' IN WIDTH, DEFINING THERE LOCATION.
4. UTILITY AND DRAINAGE EASEMENTS OF 5 FEET INSIDE ALL LOT LINES AND 10 FEET OUTSIDE ALL RIGHT-OF-WAY LINES AND INSIDE ALL PERIMETER BOUNDARIES, EXCEPT WHERE BUILDINGS ARE PLANNED.
5. BAKERTOWN STATION WAY AND TRAIN STATION WAY, AS SHOWN HEREON, ARE TO BE DEDICATED JOINT PERMANENT EASEMENTS, AND SHALL BE OWNED AND MAINTAINED BY THE HOMEOWNERS ASSOCIATION.
6. THIS PROPERTY IS NOT IN A DESIGNATED FLOOD ZONE AS SHOWN ON FLOOD INSURANCE MAP FOR KNOX COUNTY, FEMA PANEL 47093C0254F, LAST REVISED ON 02 MAY 2007.
7. ALL TELEPHONE, ELECTRICAL, AND CABLE SYSTEMS SHALL BE PLACED UNDERGROUND UNLESS THIS IS NOT ECONOMICALLY FEASIBLE IN THE JUDGMENT OF THE UTILITY COMPANY INVOLVED.
8. TRASH COLLECTION SHALL BE BY INDIVIDUAL CONTAINERS FURNISHED BY WASTE DISPOSAL SERVICE TO EACH HOME.
9. MINIMUM BUILDING SETBACKS ARE AS FOLLOWS:  
FRONT.....20'  
SIDE.....5', EXCEPT WHERE BUILDINGS ARE ATTACHED.  
REAR.....15'
10. DEVELOPER SHALL PROVIDE IN THE COVENANTS AND RESTRICTIONS A CLAUSE TO PROHIBIT THE STORAGE OF RECREATIONAL VEHICLES ON SITE, WHICH ARE VISIBLE TO OTHERS.
11. COMMON AREAS AND SPECIFIED INTERNAL ROADS SHALL BE MAINTAINED BY ESTABLISHMENT OF A HOMEOWNERS ASSOCIATION WITH A BUDGET SUFFICIENT TO MAINTAIN AND REPLACE SUCH IMPROVEMENTS.
12. CONCRETE PATIOS FOR UNITS NOT TO EXTEND INTO SETBACK AREAS IN EXCESS OF 12 FEET.
13. SEE SHEET CP-3.0 FOR LANDSCAPE DESIGN.
14. EXISTING VEGETATION ALONG PROPERTY LINES TO REMAIN AND SERVE AS BUFFER ZONES, EXCEPT WHERE UTILITIES AND STORMWATER MEASURES ARE INSTALLED, OR WHERE GRADING REQUIRES THE REMOVAL OF SAID VEGETATION.
15. CULVERTS TO BE SIZED TO CARRY A 100-YEAR STORM EVENT. ALL LOCAL AND STATE PERMITS TO BE OBTAINED PRIOR TO CONSTRUCTION.
16. TENNESSEE STATE PLANE GRID NORTH BASED ON A BEARING OF NORTH 47°20'44" EAST WHICH IS REPRESENTATIVE OF A SURVEY OF BABELAY FARM, LLC PROPERTY PREPARED BY ABBOTT LAND SURVEYING, DATED 20 JUNE 2005, AND BEARING JOB NUMBER 50104.
17. TYPICAL DRIVEWAYS TO BE A MINIMUM OF 20 FEET IN LENGTH, AND 10 FEET WIDE FOR ONE CAR GARAGES AND 15 FEET IN LENGTH, AND 16 FEET WIDE FOR TWO CAR GARAGES.
18. THE PAVEMENT WIDTH FOR ALL INTERNAL ROADS IS AS DEFINED WITHIN PAVEMENT CROSS-SECTIONS.
19. ACCESS TO ALL LOTS TO BE LIMITED TO INTERNAL J.P.E.'S ONLY.
20. KNOX COUNTY HAS APPROVED GRADES AT THE INTERSECTIONS FROM BAKERTOWN STATION WAY TO TRAIN STATION WAY AND FROM BAKERTOWN STATION WAY TO CONDUCTOR WAY.

APPROVED VARIANCES:

- 1) A VARIANCE TO REDUCE RIGHT-OF-WAY DEDICATION FROM 30' TO 25' FROM CENTERLINE FOR BALL CAMP PIKE AND BAKERTOWN ROAD WAS APPROVED BY MPC ON 08 SEPTEMBER 2005.
- 2) ON 24 SEPTEMBER 2004 THE KNOX COUNTY BZA APPROVED A VARIANCE FOR WAIVER OF PERIPHERAL SETBACK ON BAKERTOWN ROAD FROM 35' TO 25' FOR PROPOSED CONDOMINIUM PROJECT AT THE CORNER OF BALL CAMP PIKE AND BAKERTOWN ROAD.

MPC FILE #1-SF-15-C  
MPC FILE #1-J-15-UR

R=1876.98'  
L=351.55'  
CHORD DATA  
N 36°14'57" W  
CH=351.03'

LEGEND:

- PROPOSED STORM DRAIN AND CATCH BASIN STRUCTURE
- PROPOSED HEAD WALL
- PROPOSED JUNCTION BOX
- PROPOSED AREA DRAIN
- DETENTION POND
- SIGHT DISTANCE EASEMENT
- LIMITS OF UNDISTURBED STREAM BUFFER
- LIMITS OF VEGETATIVE STREAM BUFFER

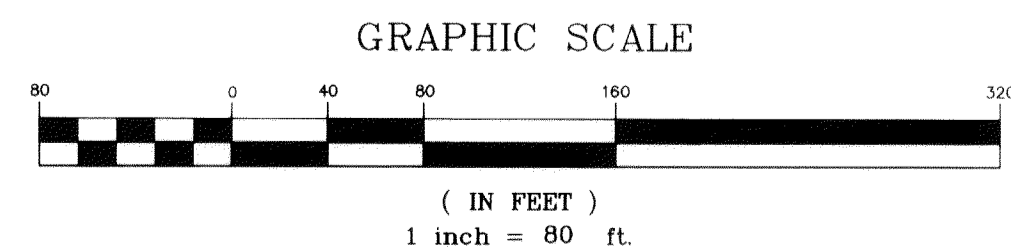

JERRY E. & NORMA J. BROCK  
PARCEL 255  
DEED BOOK 1312, PAGE 67

PROPERTIES INFORMATION

6th CIVIL DISTRICT OF KNOX COUNTY  
CLT MAP 91, PARCEL 256.01  
PORTION OF PROPERTY DESCRIPTION IN  
INSTRUMENT #200507250007480

PORTION OF LOT 1 AS SHOWN ON  
SUBDIVISION PLAT OF TRACTS I, II, AND III OF  
BALL CAMP RESIDENTIAL PARTNERS PROPERTY  
INSTRUMENT #200610310037488

OWNERS:  
BALL CAMP RESIDENTIAL PARTNERS  
355 TRANE LANE  
KNOXVILLE, TN 37931  
(865) 330-0013

CONCEPT PLAN  
and USE ON REVIEW  
FOR  
**BAKERTOWN STATION  
UNIT 2**

17.65 ± ACRES ZONED "PR 1-4 DU/AC"  
SUBDIVIDE THE 17.65 ± ACRE TRACT INTO 63 RESIDENTIAL LOTS=5.35± ACRES  
2 COMMON AREAS=8.11± ACRES  
JOINT PERMANENT EASEMENT=4.19± ACRES  
"DENSITY ~ 3.74 DU/AC~"  
DEVELOPED BY  
**BALL CAMP RESIDENTIAL PARTNERS**  
355 TRANE LANE  
KNOXVILLE, TN 37931  
(865) 330-0013

Certification of Concept Plan

I hereby certify that I am a surveyor, licensed to do surveying under the laws of the State of Tennessee. I further certify that this plan and accompanying drawings, documents, and statements conform to all applicable provisions of the Knoxville/Knox County Subdivision Regulations except as has been itemized, described and justified in a report filed with the Metropolitan Planning Commission.

*Benjamin A. Moon*  
Benjamin A. Moon, Surveyor  
Benchmark Associates, Inc. Benjamin A. Moon, No. 1501  
Tennessee No. 1501

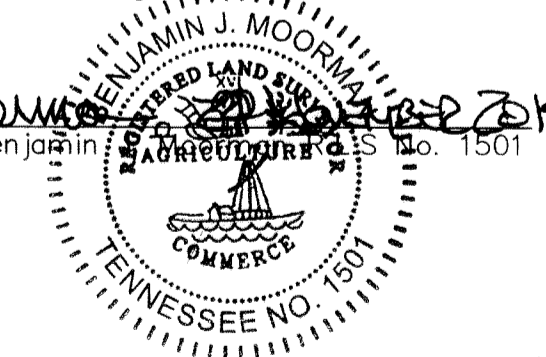

REVISED  
7-23-14

**BAKERTOWN STATION, UNIT 2**  
BALL CAMP PIKE & BAKERTOWN ROAD  
KNOXVILLE, KNOX COUNTY, TENNESSEE 37931  
For  
BALL CAMP RESIDENTIAL PARTNERS

DATE: 24 NOVEMBER 2014  
SCALE: 1" = 80'  
DRAWN BY: LGAS  
FILE NAME: 14-091-CP  
BM PROJECT NO.: 14091

CONCEPT PLAN

C-1.0

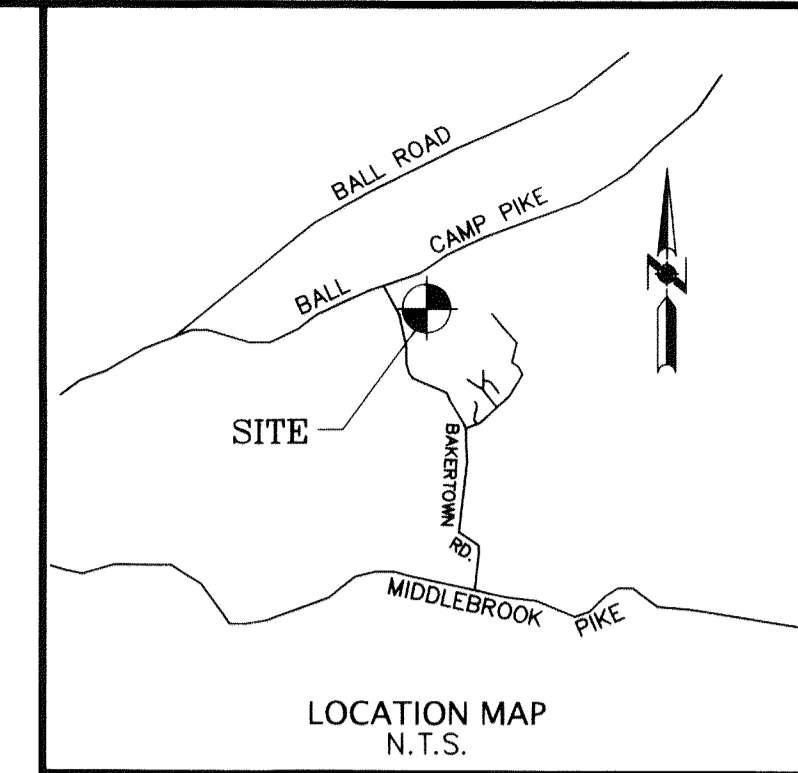

PROPOSED DEVELOPMENT UTILITIES:  
UNDERGROUND ELECTRICAL.....KNOXVILLE UTILITY BOARD  
SANITARY SEWERS.....WEST KNOX UTILITY DISTRICT  
NATURAL GAS.....KNOXVILLE UTILITY BOARD  
SANITARY WATER.....WEST KNOX UTILITY DISTRICT  
UNDERGROUND TELEPHONE.....AT & T  
STORM SEWERS.....KNOX COUNTY

10308 Middle Valley Road  
Knoxville, Tennessee 37932  
Phone (865) 692-4090  
Facsimile (865) 692-4091

**BENCHMARK ASSOCIATES, INC.**  
Land Planners & Land Surveyors

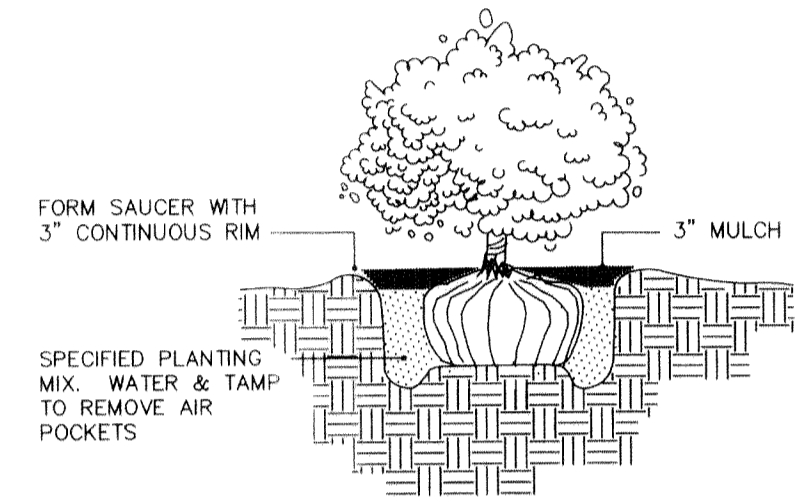
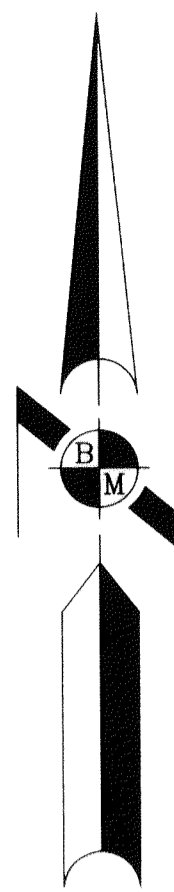

SHRUB PLANTING

SCALE: NOT TO SCALE

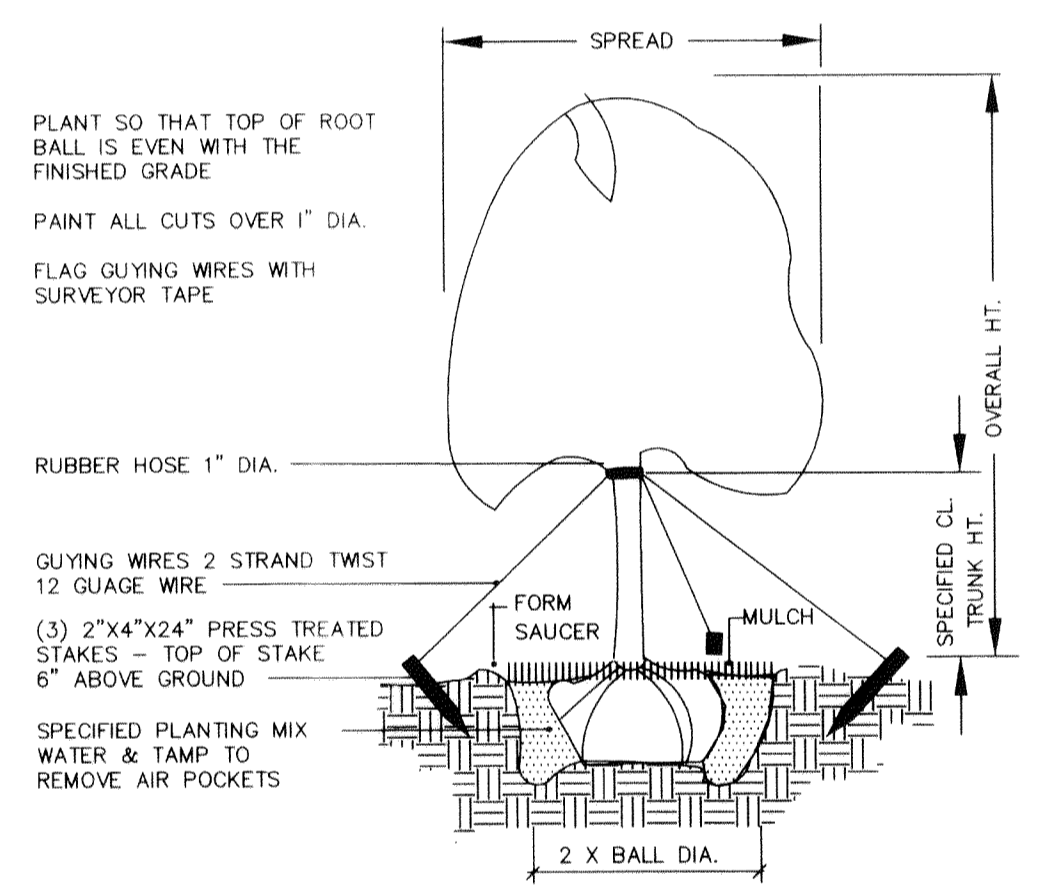

TREE PLANTING

SCALE: NOT TO SCALE

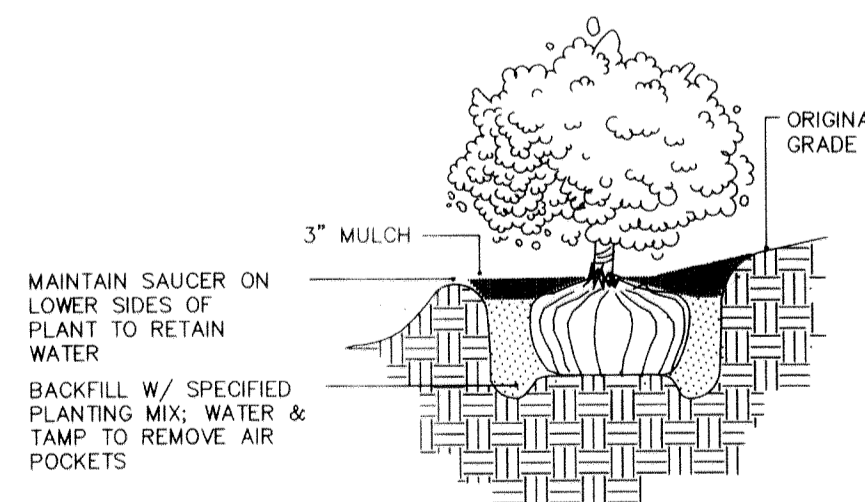

SHRUB PLANTING / SLOPES

SCALE: NOT TO SCALE

PLANTING SCHEDULE

MARK	SYMBOL	COMMON NAME	BOTANICAL NAME	MIN. SIZE
<b>TREES</b>				
PO		PIN OAK	PALUSTRIS	8" HGT. 2-1/2" CAL.
SM		SUGAR MAPLE	ACER SACCHARUM	8" HGT. 2-1/2" CAL.
FD		FLOWERING DOGWOOD	CORNUS FLORIDA "WHITE CLOUD"	8" HGT. 2-1/2" CAL.
WP		WHITE PINE	PINUS STROBUS	8" HGT. 2-1/2" CAL.
<b>SHRUBS</b>				
PL		PLANTAIN LILY	HOSTA FORTUNEI "AUREOMARGINATA"	8" SPREAD
MJ		MINT JULEP JUNIPER	JUNIPERUS CHINENSIS "MINT"	15" SPREAD
PB		CRIMSON PYGMY BARBERRY	BERBERIS THUNBERGII ATROPURPUREA NANA "CRIMSON PYGMY"	18" HEIGHT
LT		LILYTURF	LIRIOPE MUSCARI	15" SPREAD
DN		DWARF NANDINA	NANDINA DOMESTICA "FIREPOWER"	15" SPREAD
HH		HELLERI HOLLY	ILEX CRENATA HELLERI HOLLY	15" SPREAD
<b>TURF</b>				
SOD		FALCON FESCUE	SEE NOTE NUMBER 6	

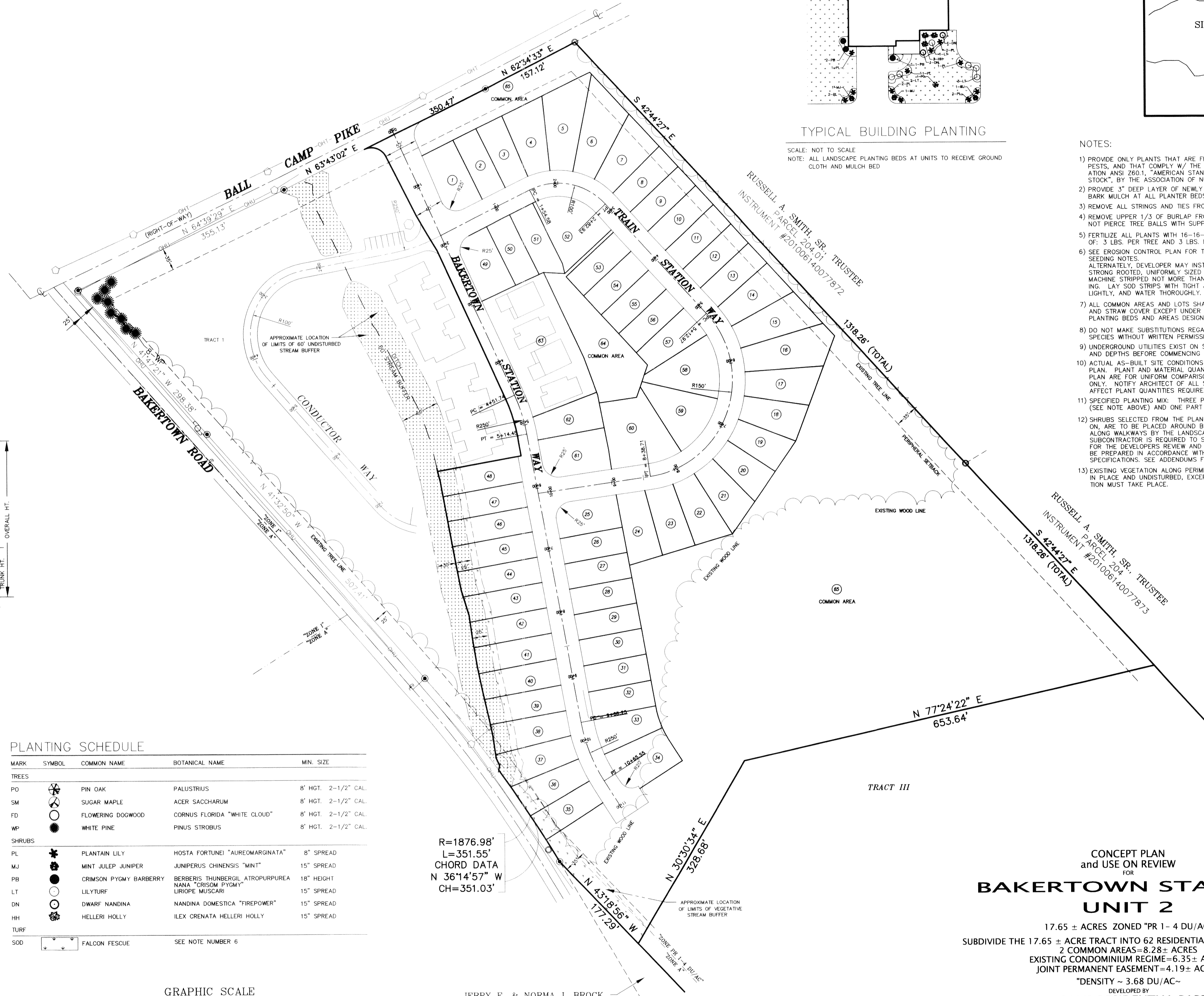
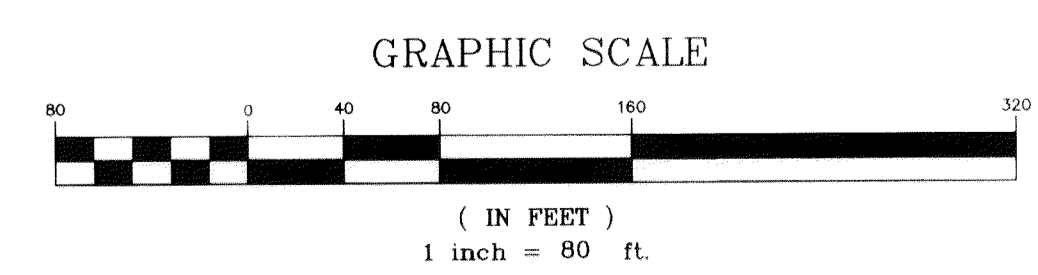

TYPICAL BUILDING PLANTING

SCALE: NOT TO SCALE  
NOTE: ALL LANDSCAPE PLANTING BEDS AT UNITS TO RECEIVE GROUND CLOTH AND MULCH BED

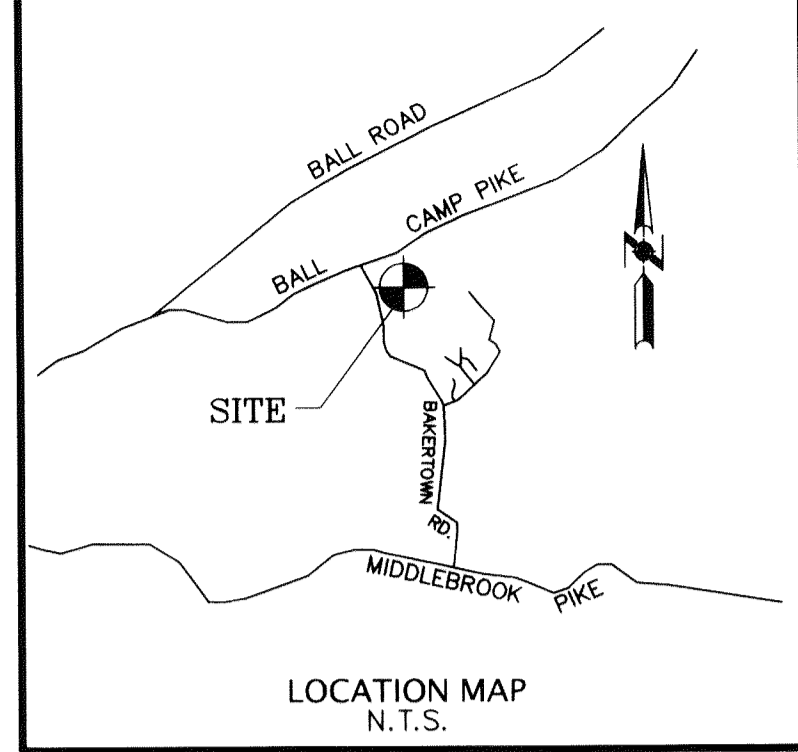

NOTES:

- PROVIDE ONLY PLANTS THAT ARE FREE FROM DISEASES AND PESTS, AND THAT COMPLY W/ THE LATEST EDITION OF PUBLICATION ANSI Z60.1, "AMERICAN STANDARDS FOR NURSERY STOCK", BY THE ASSOCIATION OF NURSERYMEN.
- PROVIDE 3" DEEP LAYER OF NEWLY SHREDDED HARDWOOD BARK MULCH AT ALL PLANTER BEDS.
- REMOVE ALL STRINGS AND TIES FROM TREES AND SHRUBS.
- REMOVE UPPER 1/3 OF BURLAP FROM ALL PLANT BALLS; DO NOT PIERCE TREE BALLS WITH SUPPORT STAKES.
- FERTILIZE ALL PLANTS WITH 16-16-16 FERTILIZER AT THE RATE OF: 3 LBS. PER TREE AND 3 LBS. PER 100 S.F. OF SHRUB BED.
- SEE EROSION CONTROL PLAN FOR TEMPORARY AND PERMANENT SEEDING NOTES.  
ALTERNATELY, DEVELOPER MAY INSTALL SOD WHICH IS CLEAN, STRONG ROOTED, UNIFORMLY SIZED STRIPS OF 2 YEAR OLD SOD. MACHINE STRIPPED NOT MORE THAN 72 HOURS PRIOR TO LAYING. LAY SOD STRIPS WITH TIGHT JOINTS, ROLL OR TAMP LIGHTLY, AND WATER THOROUGHLY.
- ALL COMMON AREAS AND LOTS SHALL RECEIVE SEEDED TURF AND STRAW COVER EXCEPT UNDER BUILDINGS, ROADS, SIDEWALKS, PLANTING BEDS AND AREAS DESIGNATED TO BE SODDED.
- DO NOT MAKE SUBSTITUTIONS REGARDING PLANT SIZES OR SPECIES WITHOUT WRITTEN PERMISSION OF THE ARCHITECT.
- UNDERGROUND UTILITIES EXIST ON SITE. VERIFY LOCATIONS AND DEPTHS BEFORE COMMENCING PLANTING WORK.
- ACTUAL AS-BUILT SITE CONDITIONS MAY VARY FROM THIS PLAN. PLANT AND MATERIAL QUANTITIES AS SHOWN ON THE PLAN ARE FOR UNIFORM COMPARISON AND ESTIMATE PURPOSE ONLY. NOTIFY ARCHITECT OF ALL SITE CONDITIONS WHICH WILL AFFECT PLANT QUANTITIES REQUIRED AND/OR THEIR LOCATIONS.
- SPECIFIED PLANTING MIX: THREE PARTS TOPSOIL, FERTILIZER (SEE NOTE ABOVE) AND ONE PART PEAT MOSS.
- SHRUBS SELECTED FROM THE PLANTING SCHEDULE, LISTED HERE-ON, ARE TO BE PLACED AROUND BUILDINGS, WITHIN ISLANDS AND ALONG WALKWAYS BY THE LANDSCAPE SUBCONTRACTOR. SAID SUBCONTRACTOR IS REQUIRED TO SUBMIT PLANS AND PROPOSALS FOR THE DEVELOPERS REVIEW AND APPROVAL. SAID PLANS MUST BE PREPARED IN ACCORDANCE WITH THE CITY OF STATESVILLE'S SPECIFICATIONS. SEE ADDENDUMS FOR PLANTING AROUND BUILDINGS.
- EXISTING VEGETATION ALONG PERIMETER BOUNDARIES IS TO REMAIN IN PLACE AND UNDISTURBED, EXCEPTING WHERE UTILITY CONSTRUCTION MUST TAKE PLACE.

CONCEPT PLAN and USE ON REVIEW FOR BAKERTOWN STATION UNIT 2

17.65 ± ACRES ZONED "PR 1 - 4 DU/AC"  
SUBDIVIDE THE 17.65 ± ACRE TRACT INTO 62 RESIDENTIAL LOTS=5.18± ACRES  
2 COMMON AREAS=8.28± ACRES  
EXISTING CONDOMINIUM REGIME=6.35± ACRES  
JOINT PERMANENT EASEMENT=4.19± ACRES  
"DENSITY ~ 3.68 DU/AC~"  
DEVELOPED BY  
**BALL CAMP RESIDENTIAL PARTNERS**  
355 TRANE LANE  
KNOXVILLE, TN 37931  
(865) 330-0013

**BENCHMARK ASSOCIATES, INC.**  
Land Planners & Land Surveyors

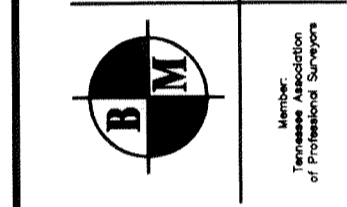

**BAKERTOWN STATION, UNIT 2**  
BALL CAMP PIKE & BAKERTOWN ROAD  
KNOXVILLE, KNOX COUNTY, TENNESSEE 37931  
For  
**BALL CAMP RESIDENTIAL PARTNERS**

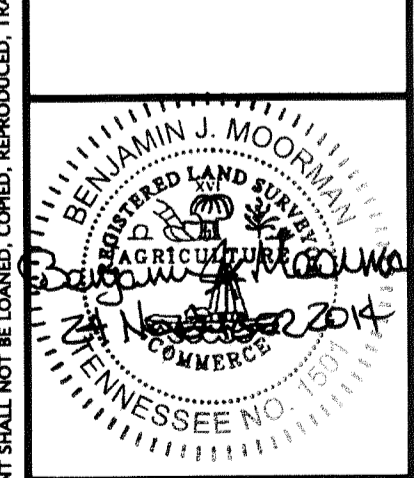

DATE: 24 NOVEMBER 2014  
SCALE: 1" = 100'  
DRAWN BY: LCAS  
FILE NAME: 04091-LS  
PROJECT NO.: 14091

**PRELIMINARY LANDSCAPE PLAN**

**C-3.0**